



Figure 1 Mecon Orifice Flow Meter TM N4

## Application

The TM N4 orifice flow meter is used to measure the flow of transparent liquids in closed piping. Any mounting location, position and flow direction can be selected for the flow meter. The flow meter can also be used for flow monitoring if equipped with limit contacts.

- Potable water preparation
- Swimming pool technology
- Swimming pool technology
- Gas insert measurement
- Installation in plastic pipe systems

## Special Features

- Any mounting location of the orifice unit
- Simple mounting and handling
- Reasonable plastic design
- Short delivery times for standard versions.

## Design and Mode of Operation

The TM N4 orifice flow meter primarily consists of an orifice plate as the sensor and a float as the display element. A differential pressure is produced across the orifice plate which is fitted in the main stream between two flanges in the piping. In a bypass, this differential pressure produces a volume flow in a rotameter. The height of the float indicates the flow rate. The flow is read at the position of the float's widest diameter.

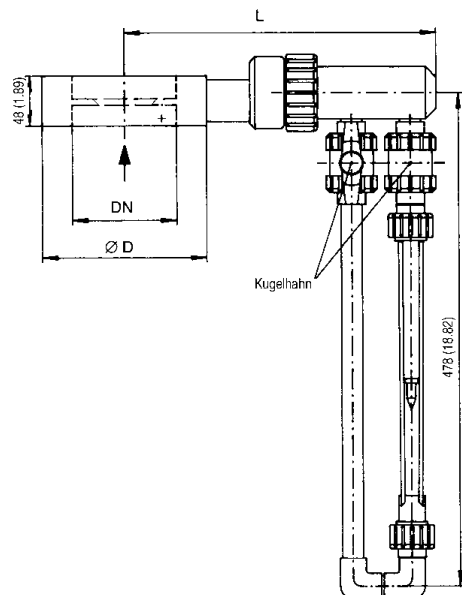

Figure 2 TM N4 design

## Technical Data

TM N4 (Orifice flow meter)		
Liquid	min.	1.2 - 6 m <sup>3</sup> /h
	max.	320 - 1.600 m <sup>3</sup> /h
	min.	5.28 - 26.42 USgpm
	max.	1,409 - 7,045 USgpm
		transparent
Pressure	max.	10 bar, 145 psi
Temperature	max.	+60 °C, 140 °F
Accuracy		± 2.0 % of full scale value
Installation position		any mounting location (orifice unit)
Flow direction		any flow direction
Connections		DN 40 - 400
		ANSI 1½" - 16"
Accessories		switching contacts
PED 97/23/EC	Cat.	Art. 3.3 (liquids of fluid group 2)

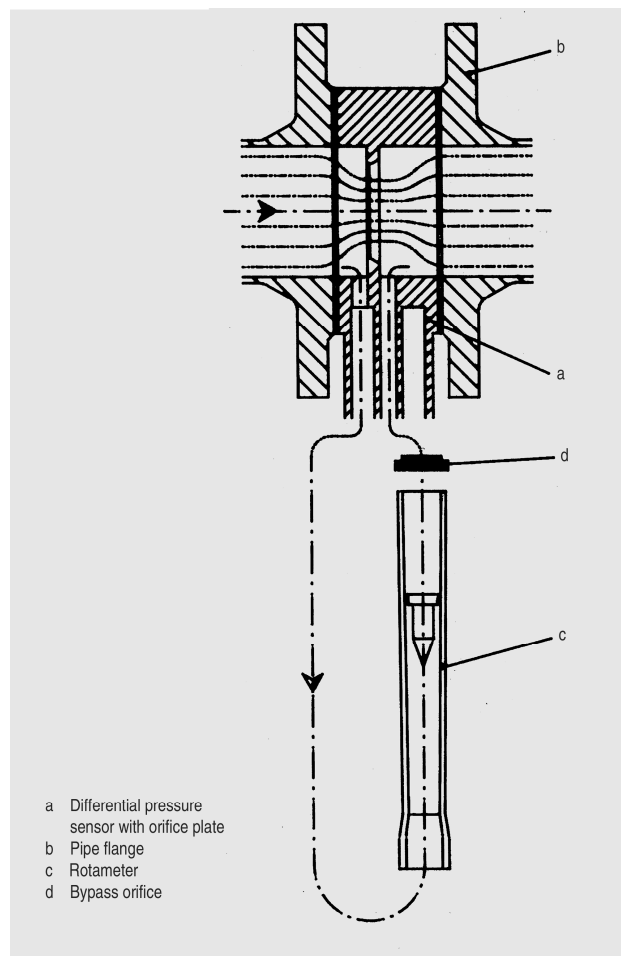

Figure 2 Measuring principle

Please contact [sales@tecmara.de](mailto:sales@tecmara.de) for further information to this product.