



Figure 1 Automatic-Recirculation-Check Valve SSV 10 / SSV 12

Application

The Automatic-Recirculation-Check Valve (AR-Valve) is a pump protection device. It automatically protects centrifugal pumps from damage which might occur through partial evaporation of the fluid content during low load operation.

- Power Stations, Nuclear Power Stations
- Chemical industry
- Petrochemical industry
- Off-Shore-Industries
- Steel works
- Paper industry
- Fire fighting systems
- Snow producing systems
- In the potable water supply and backwater disposal

Design and Operation

For the main flow - to the process - the valves have an inlet flange DN₁ and an outlet flange DN₂. The minimum flow is going out through an additional branch DN₃ back to the reservoir.

As soon as the pump capacity drops below a predetermined flow rate, the AR-valve opens sufficiently the bypass to maintain the pump minimum flow rate. This rate is maintained even if the flow in main direction to the boiler or process is completely shut off.

The AR-valve automatically opens and closes the bypass corresponding to the main flow rate. This **flow controlled** function operates without additional auxiliary energy.

The pressure and flow reduction to the minimum flow requirements in the bypass line takes place through a multistage throttle system.

Advantage and Utility

- assurance of the required pump minimum continuous safe flow no inadmissible temperature increase in the pump; avoidance of cavitations in the pump; avoidance of pump and plant damages
- integrated non-return valve in the main delivery stream avoidance of reverse operation of the pump; allows parallel pump operation
- specifically designed throttle system in the bypass (low cavitations) reduces pressure and flow rate to minimum flow requirements
- favorable NPSH-value of the plant (NPSH_A) and the pump (NPSH_R) lower capacity in operating point because of automatic closure of the minimum flow line
- lower prime mover power requirement
- lower facility costs

Special Features

- modulating bypass control with low wear by the „Rotary-Valve-Design“
- non-return-function in main direction to the process
- multistage reduction of pressure and flow rate in the bypass - low cavitations and of low noise
- without additional auxiliary energy and measuring technique
- less pressure loss
- mounting position vertical* or horizontal
- all internal parts are made out of stainless steel
- reliable and durable

Technical Data SSV 10 / SSV 12

Medium

Fluids without solids

Viscosity ≤ 150 cSt

Temperature -10 °C up to +300 °C*
-14 °F up to +572 °F*

Engineering Specification

Nominal width DN

- main direction 25 up to 300 mm; (1" up to 12")*
- bypass 15 up to 150 mm (0,5" up to 6")*

Pressure rate PN 10 up to PN 320*
ANSI 150 up to ANSI 2500 lbs*

Bypass control modulating with throttle

Material casing parts 1.0460 (A105)* ASME in ()
1.0566 (A350-LF2);
1.4301 (A182-F304);
1.4541 (A276-321);
1.4571 (A276-316TI);
1.4404 (A182-F316L);
1.4462 (A182-F51);
further materials by request

Material internals stainless steel*

Connection Flanges according to DIN / ANSI*
Sealing and connection parts are not scope of supply

Mounting position vertical* or horizontal

Operating Condition

Pressure difference between inlet (DN₁) and Bypass branch (DN₃) max. 200 bar (40 bar SSV12)
max. 2900 psi (580 psi SSV12)

Flow rate main direction 5 m³/h up to 2000 m³/h*
22 USgpm up to 8800 USgpm*

Flow rate bypass up to 630 m³/h* (2775 USgm)*
35%, max. 50% of main flow rate is advised*

Flow velocity max. 10 m/s (flange)

Pressure loss in the valve (applied to main flow) 0,5 bar (low pressure)
up to 1,3 bar (high pressure)

* standard version, more by request

Design

The construction is according to specification AD 2000 and particularly to EN 13445. As per Pressure Equipment Directive 97/23 EC the products are provided with the CE marking and the Declaration of Conformity. Certified according to the Module H1 (Pressure Equipment Directive 97/23 EC) all dangerous material classes of category 1 to 4 are covered.

Installation and Connection

The AR-valve is produced and tested only for the ordered data according the customer data sheet. Following points have to be alluded:

- Mounting direct on the pump discharge branch (advised)
- Pipes have to be connected free of stress, without offset, mismatch or longitudinal shifting
- The pipe system must be cleaned and free of soiling
- Installation has to be in the ordered mounting position
- To maintain the valve and to calm down the flow a piece of straight pipe with a length of 1 meter (40") has to be installed at the bypass branch DN₃ and at the outlet branch DN₂
- The bypass pipe has to be filled with medium anytime
- The supplied installation and operating instructions has to be followed

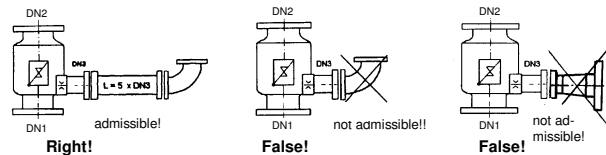

Figure 2 Mounting with straight pipe piece

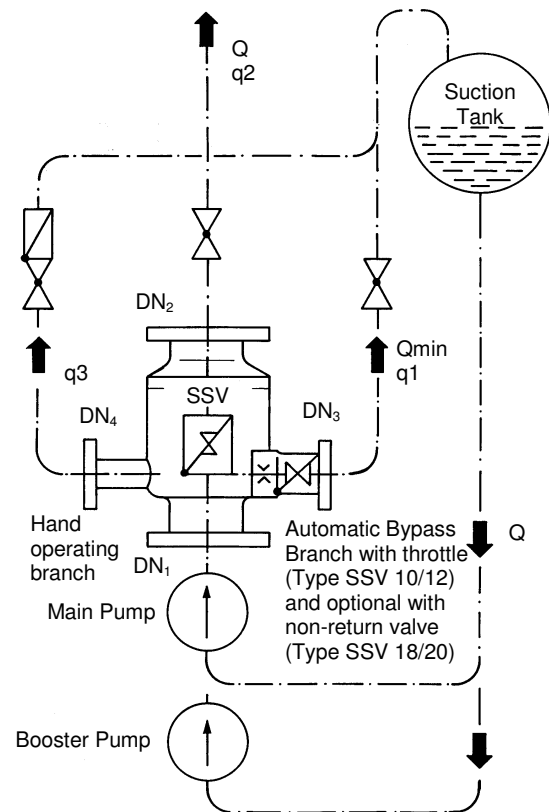

Figure 3 Bypass Return with additional hand operated branch (optional)

Note of Application

The operator of these fittings is responsible for suitability, proper use and corrosion resistance of the used materials with regard to the used fluid. It must be ensured that the materials selected for the fitting parts in contact with the medium are suitable for the used process media. The fitting may only be used for the application specified in the operating instructions and the data sheets. Provide a touch guard for surface temperatures of < -10 °C or > +50 °C. This touch guard must be designed in a way that the max. allowable ambient temperature on the unit is not exceeded. Before replacing the valve, check that the unit is free of hazardous media and pressures.

Type Designation of the Valves

The designation of the valve specifies the type, nominal width and pressure rate, the flange sizes and the mounting position.

Example:

	SSV 10-50/160	-50/50/15/0-1
	SSV 10-2" ANSI900	-2/2/0,5/0-1
Valve type	↑	↑
with throttles in bypass 10		
with throttles in bypass 12		
Valve size	↑	↑
DN 50 mm	50	
DN 2" (ANSI)	2"	
Pressure rate		↑
160 bar		160
900 lbs. (ANSI)		ANSI900
Flange sizes		↑
inlet DN ₁ 50 mm		50
inlet DN ₁ 2" (ANSI)		2
outlet DN ₂ 50 mm		50
outlet DN ₂ 2" (ANSI)		2
bypass DN ₃ 15 mm		15
bypass DN ₃ 0,5" (ANSI)		0,5
additional branch		0
no additional branch		1
mounting (applied to main flow)		↑
vertical		1
horizontal		2

2/4

SSV 12

The type SSV 12 corresponds technically with the SSV 10 and will be supplied with a larger bypass. This is required for larger bypass flows up to 40 bar differential pressure. The choice will be done factory-made.

Marking of the Valve

The Automatic-Recirculation-Check Valve has the following name plate with all relevant valve data.

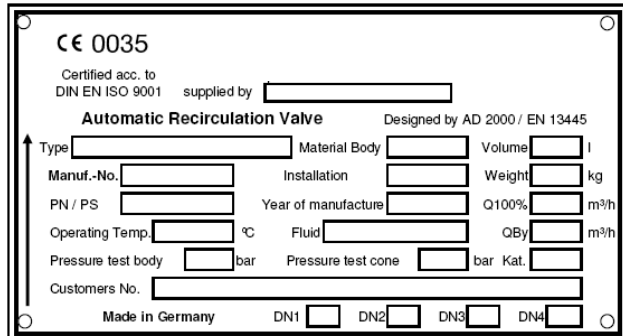

CE 0035
Certified acc. to
DIN EN ISO 9001 supplied by

Automatic Recirculation Valve Designed by AD 2000 / EN 13445

Type Material Body Volume l

Manuf.-No. Installation Weight kg

PN / PS Year of manufacture Q100% m³/h

Operating Temp. °C Fluid QBy m³/h

Pressure test body bar Pressure test cone bar Kat.

Customers No.

Made in Germany DN1 DN2 DN3 DN4

Figure 4 Name plate mounted to the fitting

Accessories

The **hand operating branch** with multiport-throttle is fitted at the casing below the cone seat and serves to pass off the minimum flow via a hand-operated valve combination. We recommend the branch for protection of the internal bypass parts at extreme operating conditions, e.g. at high differential pressures and frequent operation in the range of bypass flow as well as for filling and start-up of the plant.

Start-Up-Trim (SUT) substitutes the bypass valve head during cleaning and start-up of plants and therefore spares the sophisticated regulating parts (optional, permanently open bypass outlet). Also usable instead of the hand operating branch.

Warm-up branch, pressure gauge branch, draining branch etc. can be provided, if required.

The **pressure device SPD** avoids cavitations and flashing in piping. The function corresponds to a variable throttle which adjusts oneself to the flow rate.

The **damping valve SRV** will be applied to absorb pressure shocks during recurrent on/off operation e.g. for descaling facilities at steel mills. The SRV has to be mounted direct to the AR-Valve.

Parts List SSV 10/12 with Throttles

Part-#	Designation	Materials
1	Lower body	
2	Upper body	
3	Cone	
4	Cone guide	
5	Cone guide	
10	Bypass branch	
12	Valve head casing	
13	Rotary slide valve	
14	Operating lever	according to operating conditions and valid standards
15	Throttle	
24	Hand-op. branch	
25	Multi-port throttle	
78.1	O-Ring	
78.2	O-Ring	
91.1	Socket screw	
91.2	Socket screw	
94.1	Dowel pin	
94.2	Dowel pin	
95.1	Coil spring	

Wear and Spare Parts

Bypass Valve Head, complete	
Casing	Part-# 12
Rotary slide valve	Part-# 13
Operating lever	Part-# 14
Dowel pin	Part-# 94.1
Dowel pin	Part-# 94.2
Throttle in the Bypass Branch	
Throttle	Part-# 15
O-Ring	Part-# 78.2
Single Spare Parts	
O-Ring	Part-# 78.1
Coil spring	Part-# 95.1

3/4

With reservation to changes

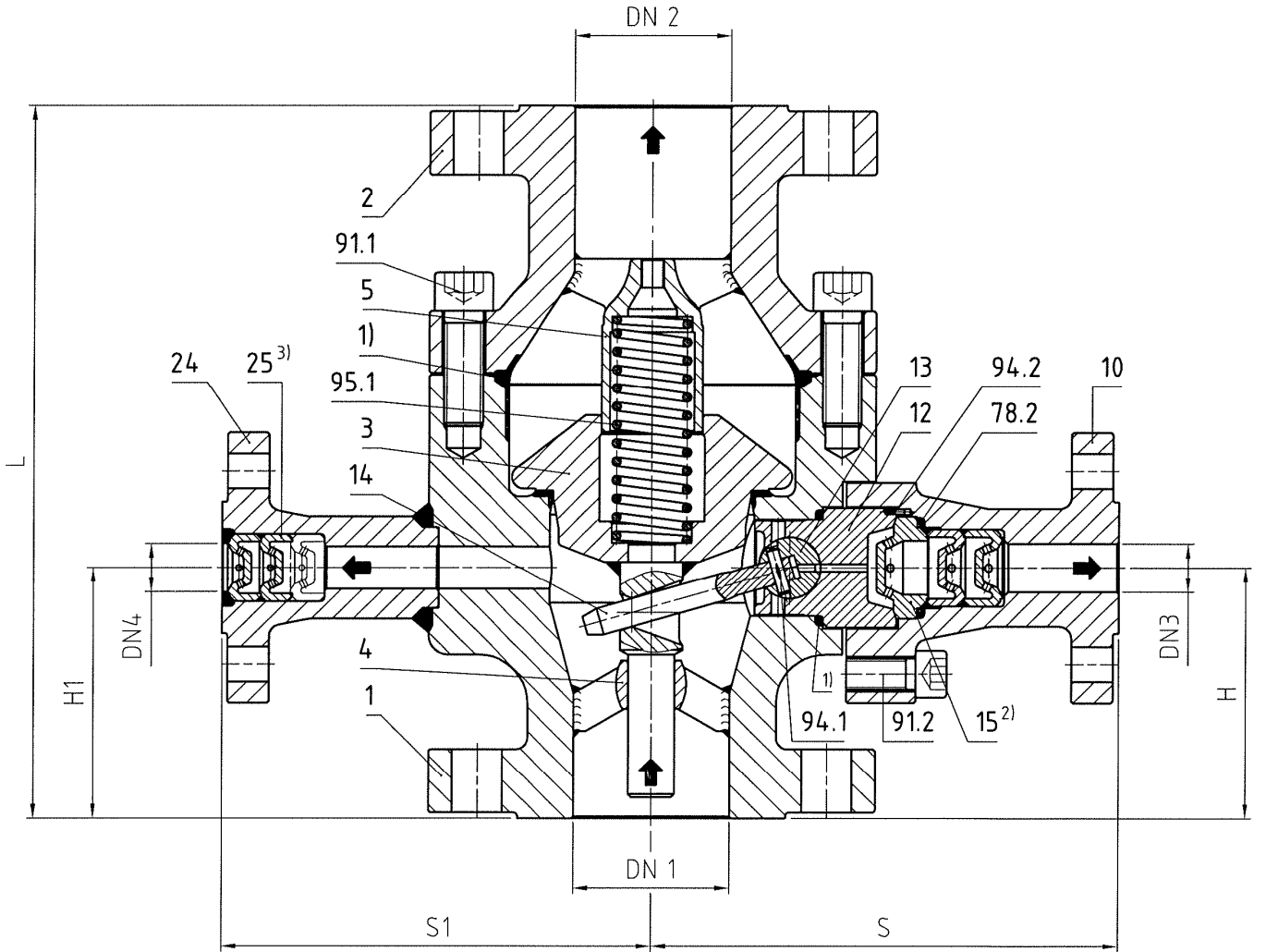

4/4

Figure 5 SSV 10/12 with multistage pressure and flow reduction in the bypass