

- Sizes :** ½" to 12"
- Pressure:** ASME 300 lbs
- Flanges:** ASME B16.5 RF
- Features:**
- Integrally cast housing
 - Bolted cover c/w drain plug
 - Red oxide finish (Carbon Steel only)
 - Ø 3 mm perforated hole plate as standard
- Advantages:**
- Largest filtration area on the market
 - Very low pressure losses
 - Extended cleaning intervals
 - European design
- Options:**
- Special screens and special gaskets
 - D.P. tappings/gauge
 - Magnetic screen insert
 - Flanged drains / drain valves
 - Special finish / linings
- Standards:** PED 2014/68/EC
CE-Marking
EN 10204 / NACE Certification

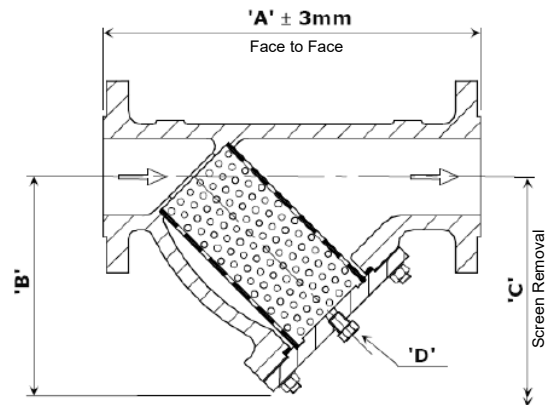

All data is subject to confirmation at the time of order. Our policy is one of continual improvement and we reserve the right to amend details without prior notice.

Technical Data

Size		Dimensions				Screen Area [cm ²]	Weight (kg)
mm	Inch	A	B	C	D (NPT)		
15	½"	175,0	95,0	165,0	½"	80,0	3,5
20	¾"	175,0	95,0	165,0	½"	80,0	4,5
25	1"	195,0	110,0	185,0	½"	126,5	7,0
40	1½"	275,0	140,0	230,0	½"	199,0	12,0
50	2"	315,0	180,0	285,0	½"	333,0	18,5
80	3"	405,0	220,0	355,0	½"	574,5	37,5
100	4"	490,0	260,0	410,0	½"	923,4	70,0
150	6"	582,0	340,0	552,0	¾"	1894,0	130,0
200	8"	730,0	440,0	705,0	¾"	2870,0	240,0
250	10"	910,0	600,0	1000,0	¾"	5000,0	430,0
300	12"	1070,0	640,0	1040,0	¾"	6375,0	720,0

Materials of Construction

Item	LT Carbon Steel	Carbon Steel	Stainless Steel
Strainer Body	ASTM A352 LCB/LCC Dual Cert	ASTM A216 WCB (~1.0619)	ASTM A351 CF8M (~1.4408)
Strainer Cover*	ASTM A352 LCB/LCC Dual Cert	ASTM A516 Gr60 / A216 WCB	ASTM A240 316 / A351 CF8M (~1.4408)
Drain Plug (forged)	ASTM A350 LF2	ASTM A105N (~1.0460)	ASTM A182 F316 (~1.4404)
Cover Stud Bolts	ASTM A320 L7M – zinc plated	ASTM A193 B7M – zinc plated	
Cover Full Nuts	ASTM A194 Gr.7M – zinc plated	ASTM A194 2HM – zinc plated	
Cover Gasket (flat)	SS 316/Graphite as Standard	C.N.A.F. as standard / to customer specification	
Screen (perforated)	SS 316 (~1.4404) (Ø 3 mm perforated hole plate as standard / to customer specification)		

*The strainer cover may be furnished from plate or casting depending upon size/availability.

Model Number Derivation:

A* / R30 / *** / YMD**

Denotes the size, i.e. add '025' for a 1"

352 for Low Temperature Carbon Steel
216 for Carbon Steel
351 for Stainless Steel